

JHMs and HJHMs are one piece non-welded joist hangers for supporting timber joists, beams and trussed rafters from masonry walls.

- Built-in inspection slot at the base of the hanger to aid inspection from the ground.
- HJHM: Heavy duty masonry hanger for higher load carrying capacity.
- Top flange provides widest area in contact with masonry support allowing superior performance. Embossments on JHM stiffen top flange and holes allow improved mortar keying.
- JHM side flange on deeper hangers is much higher than traditional style, providing greatly enhanced resistance to joist rotation.
- Regularised Timber: we have added new sizes to our JHM range to suit regularised timber. Use 47mm or 91mm width hangers for this new application.

#### Material:

JHM and HJHM: Pre-galvanised mild steel.

#### Installation:

- Use all specified fasteners. See "General Notes" (page 12).
- Set hanger back flange tight against block wall when built to desired level, then continue with additional courses to complete wall height. Joist should be tight into back of hanger when possible. Maximum gap permitted is 6mm.
- **MINIMUM 3 COURSES OF SOLID BLOCK (675MM MASONRY) REQUIRED ABOVE HANGER WITH MORTAR FULLY CURED BEFORE APPLYING LOAD.**
- Do not stack blocks or heavy loads on the joists during construction unless the joists have additional support to take the full load of the blocks vertically and horizontally.
- The JHM joists hangers can be fixed to steel beams by means of power actuated fasteners.
- The shot-fired pins must be installed by a qualified person in accordance with the manufacturer's installation requirements.

#### Options

- Return configuration provides additional support by wrapping around three sides of the block. Designate "return" and length of return dimensions when ordering.
- **RETURN HANGERS DO NOT SATISFY THE REQUIREMENTS FOR LATERAL RESTRAINT TYPE HANGERS.**
- Straddle configuration provides two hangers connected across top of support enabling exact alignment on both sides of supporting wall. Designate "straddle" and length of straddle dimensions when ordering.

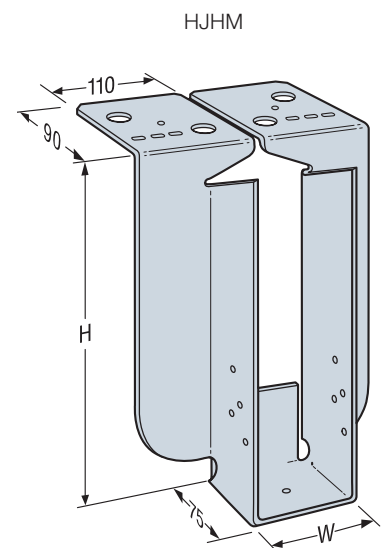
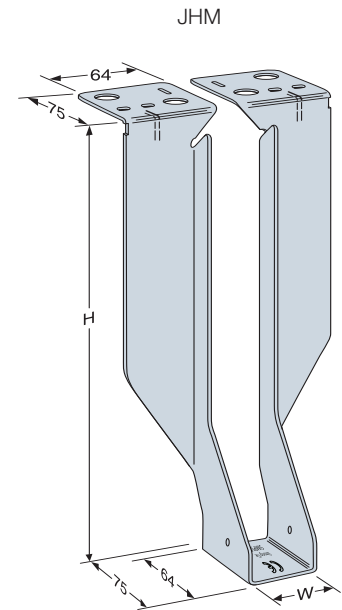

#### JHM Shot Fired to a Steel Girder

Model No.	Fasteners		Safe Working Load (kN)
	Steel Support	Joist Nails	
JHM	4 - Shot Fired Pins	4 - 3.75 x 30mm	5.17

1. The above Safe Working Loads are based upon product tests using four No. Hilti 12mm X-EDNI steel pins fired through holes provided in the top flange of the hangers onto 4mm thick steel plate. Other pins may be used provided similar structural performance is verified by the pin manufacturer.
2. Pin Head size must be sufficient to prevent pull through during loading.
3. The designer must ensure that the steel support member will support the imposed loads.
4. Install shot-fired pins in accordance with manufacturer's instructions.

JHM Shot-fired to steel

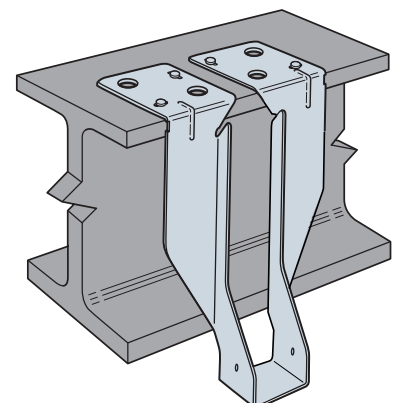

**JHM HANGERS FOR TIMBER AND TRUSS**

Joist Size		Model No.	Hanger Dimension (mm)	
Width	Height		Width (W)	Height (H)
35	100	JHM100/38	38	100
	125	JHM125/38	38	125
	150	JHM150/38	38	140
	175	JHM175/38	38	165
	200	JHM200/38	38	190
	225	JHM225/38	38	215
	250	JHM250/38	38	240
47	100	JHM100/47	47	100
	125	JHM125/47	47	125
	150	JHM150/47	47	140
	175	JHM175/47	47	165
	200	JHM200/47	47	190
	225	JHM225/47	47	215
	250	JHM250/47	47	240
50	100	JHM100/50	50	100
	125	JHM125/50	50	125
	150	JHM150/50	50	140
	175	JHM175/50	50	165
	200	JHM200/50	50	190
	225	JHM225/50	50	215
	250	JHM250/50	50	240
63	125	JHM125/63	63	125
	150	JHM150/63	63	140
	175	JHM175/63	63	165
	200	JHM200/63	63	190
	225	JHM225/63	63	215
	250	JHM250/63	63	240
2ply 35 or 75	100	JHM100/75	75	100
	125	JHM125/75	75	125
	150	JHM150/75	75	140
	175	JHM175/75	75	165
	200	JHM200/75	75	190
	225	JHM225/75	75	215
	250	JHM250/75	75	240
2ply 44 or 91	100	JHM100/91	91	100
	125	JHM125/91	91	125
	150	JHM150/91	91	140
	175	JHM175/91	91	165
	200	JHM200/91	91	190
	225	JHM225/91	91	215
	250	JHM250/91	91	240
2ply 50 or 100	100	JHM100/100	100	100
	125	JHM125/100	100	125
	150	JHM150/100	100	140
	175	JHM175/100	100	165
	200	JHM200/100	100	190
	225	JHM225/100	100	215
2ply 63	125	JHM125/125	125	125
	225	JHM225/125	125	215
3ply 50 or 2ply 75	175	JHM175/150	150	165
	225	JHM225/150	150	215

**HJHM HANGERS FOR TIMBER AND TRUSS**

Joist Size		Model No.	Hanger Dimension (mm)	
Width	Height		Width (W)	Height (H)
2ply 35 or 75	150	HJHM150/75	75	140
	175	HJHM175/75	75	165
	200	HJHM200/75	75	190
	225	HJHM225/75	75	215
	250	HJHM250/75	75	240
	300	HJHM300/75	75	290
	2ply 50 or 100	150	HJHM150/100	100
175		HJHM175/100	100	165
200		HJHM200/100	100	190
225		HJHM225/100	100	215
250		HJHM250/100	100	240
300		HJHM300/100	100	290
2ply 63	150	HJHM150/125	125	140
	200	HJHM200/125	125	190
	225	HJHM225/125	125	215
3ply 50 or 2ply 75	150	HJHM150/150	150	140
	200	HJHM200/150	150	190
	225	HJHM225/150	150	215
	250	HJHM250/150	150	240
3ply 63	225	HJHM225/190	190	215
4ply 50 or 2ply 100	150	HJHM150/200	200	140
	200	HJHM200/200	200	190
	225	HJHM225/200	200	215
	250	HJHM250/200	200	240
3ply 75	225	HJHM225/225	225	215

Typical JHM Installation

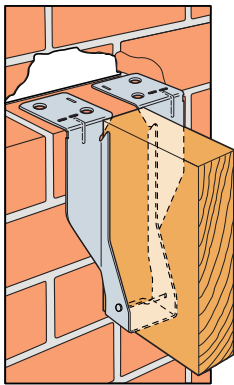

JHMS Straddle Configuration

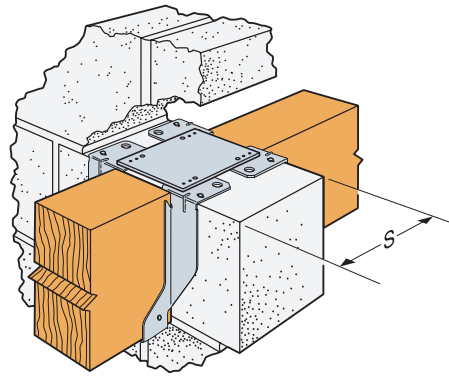

JHMR Return Configuration

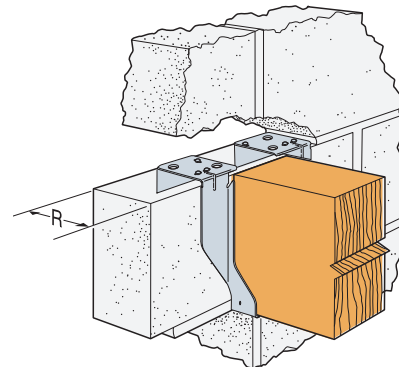

## JHM HANGERS - LOADS

Model	Joist Fasteners		Safe Working Loads (kN)			Characteristic Capacity (kN)		
			Block Strength			Block Strength		
	Qty	Nail	2.8N/mm <sup>2</sup> Solid AAC	3.5N/mm <sup>2</sup> Solid LAC	7N/mm <sup>2</sup> Solid DAC	2.8N/mm <sup>2</sup> Solid AAC	3.5N/mm <sup>2</sup> Solid LAC	7N/mm <sup>2</sup> Solid DAC
JHM <sup>(1)</sup> / <sub>(2)</sub>	2	3.75x30mm	5.29	6.48	9.37	10.59	12.97	13.98

1. Loads are based upon tests conducted by CERAM Building Technology and are determined in accordance with EN 845.
2. Loads apply to masonry blocks with a minimum compressive strength as indicated.
3. The block thickness must be at least the same size as the top flange depth (as shown in relevant illustrations).
4. For straddle hangers the minimum S dimension is 100mm.
5. 3.75 x 30mm refers to a square twist nail (not supplied with hanger).

## HJHM HANGERS - LOADS

Size Range (mm)		Joist Fasteners		Safe Working Loads (kN)			Characteristic Capacity (kN)		
Width	Height			Block Strength			Block Strength		
Width	Height	Qty	Nail	2.8N/mm <sup>2</sup> Solid AAC	3.5N/mm <sup>2</sup> Solid LAC	7N/mm <sup>2</sup> Solid DAC	2.8N/mm <sup>2</sup> Solid AAC	3.5N/mm <sup>2</sup> Solid LAC	7N/mm <sup>2</sup> Solid DAC
40 - 74	140 - 400	2	3.75 x 30mm	8.01	8.01	15.00	16.02	16.02	30.01
75 - 200	140 - 400	2	3.75 x 30mm	14.84	14.84	15.00	29.67	29.67	30.01
91 - 200	140 - 400	8	4.00 x 90mm	14.84	14.84	20.88	29.67	29.67	41.76
201 - 300	140 - 400	2	3.75 x 30mm	8.15	8.15	16.67	15.11	15.11	33.34

1. Test conducted by CERAM Building Technology in accordance with EN846-4 and evaluated in accordance with EN845-1.
2. 3.75 x 30mm refers to square twist nails.
3. Loads apply to solid block with minimum compressive strengths indicated. The block thickness must be at least the same size as the top flange length, as shown in the illustrations above. For straddle hangers the minimum S dimension is 100mm to achieve published loads, except for HJHM hangers which must be twice the top flange length of a single hanger.

## SKewed JHM HANGERS - LOADS

Model	Joist Fasteners		Safe Working Loads (kN)		
			Block Strength		
	Qty	Nail	2.8N/mm <sup>2</sup> Solid AAC	3.5N/mm <sup>2</sup> Solid LAC	7N/mm <sup>2</sup> Solid DAC
JHM	4	3.75x30mm	5.05	5.17	5.17

1. Maximum width 61mm.
2. Maximum skew 45°.